

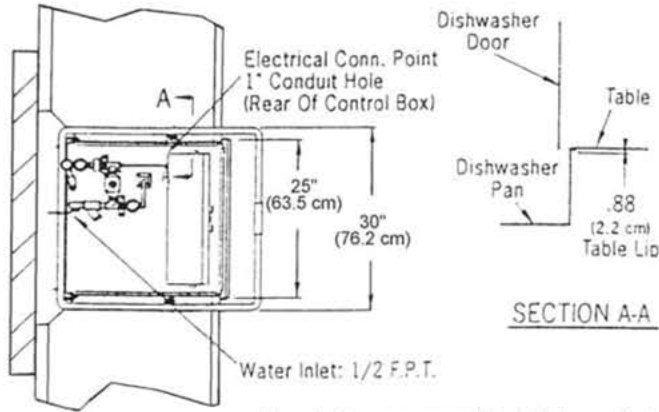

A System of Service.



www.TERMAC.com  
1.800.332.4912



**TOP VIEW**

\* Manufacturer reserves the right to modify these specifications in compliance with regulatory agencies and manufacturing expediency.

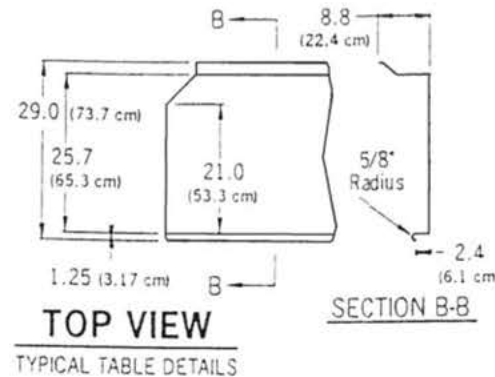

**CAUTION:**

Electrical and plumbing connections must be made by a qualified Service Person who will comply with all available federal, state, and local Health, Electrical, Plumbing, and Safety Codes.

**NOTE:** All Three Doors Open in Unison for Inspection & Cleaning Purposes and Allows for Inline or Corner Applications without Conversion Procedures.

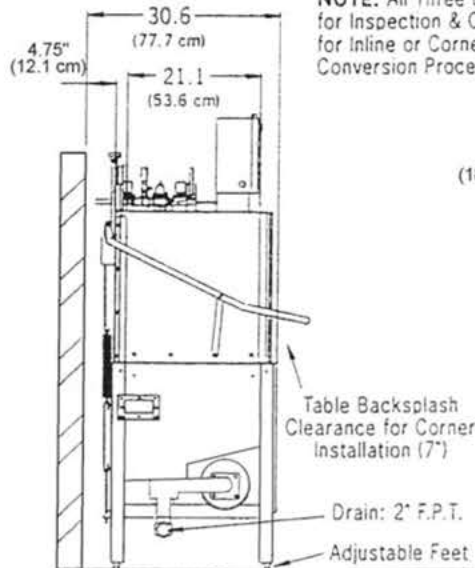

**SIDE VIEW**

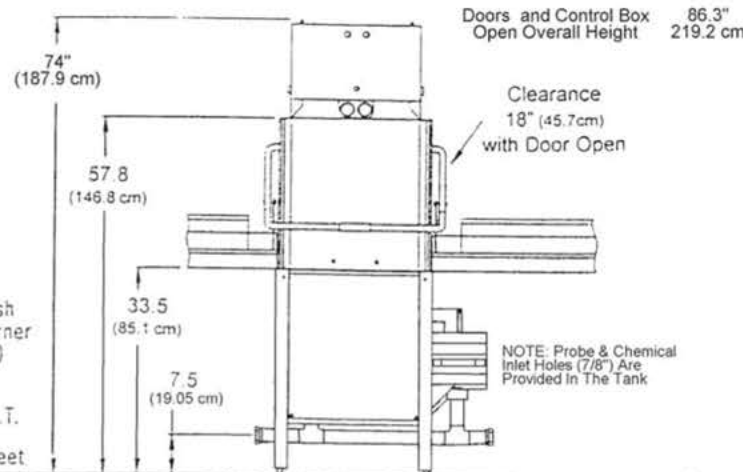

**FRONT VIEW**

**NOTE:** All dimensions listed have a tolerance of + or - 1/8" unless otherwise noted.

**MODEL HT-25 SPECIFICATIONS**

U.S. REGISTERED PATENTS

Rated Capacity (Racks/Hour)	72 NSF Rated
Wash Tank Capacity	11 Gal. (41.63 Liters)
Water Temperature, Wash	160° F. (71° C.)
Water Temperature, Rinse	180° F. (82.2° C.)
Water Consumption	0.85 Gallons/Rack (3.593 Liters/Rack)
Wash Motor	3 HP

**ELECTRICAL REQUIREMENTS:** 3-PH, 208/240V, 40amp, 60 Hz  
5-wire connection (neutral, ground, 3 #8 power wires, 50a capacity)  
Single PH: 208/240V, dual circuits 60/30 amp, 60 Hz  
Circuit 1: (neutral, ground, 2 #10 ga. wires, 40a capacity)  
Circuit 2: (2 #6 ga. wires, 75a capacity)

**HT-25/HT-34 W/FACORY INSTALLED BOOSTER: (3-Ph Only) single point Connection req's 208/240V, 3Ph, 50a, 5-wire connection (Neutral, Ground, 3 #8 ga. power wires, 65 a capacity) High leg goes to L-3**

Wash Heater	8KW
Rack Size	19-3/4" x 19-3/4" (50.2 cm x 50.2 cm)
Door Clearance	18" (45.72 cm)
Water Inlet (1)	1/2" F.P.T.
Drain	2" F.P.T.
Height (All Doors Closed)	74" (187.96 cm)
Width, Table to Table (Inline Model)	25" (63.5 cm)
Width w/ Scrap Accumulator (Overall)	37" (93.9 cm)
Depth (Overall)	33.5" 85.0 cm
Shipping Weight	485 lbs. (219.9 kg.)
Shipping Volume	81.51 cu. feet