

CAUTION:

Electrical and plumbing connections must be made by a qualified Service Person who will comply with all available federal, state, and local Health, Electrical, Plumbing, and Safety codes.

*Manufacturer reserves the right to modify these specifications in compliance with regulatory agencies and manufacturing expediency.

TYPICAL TABLE DETAILS

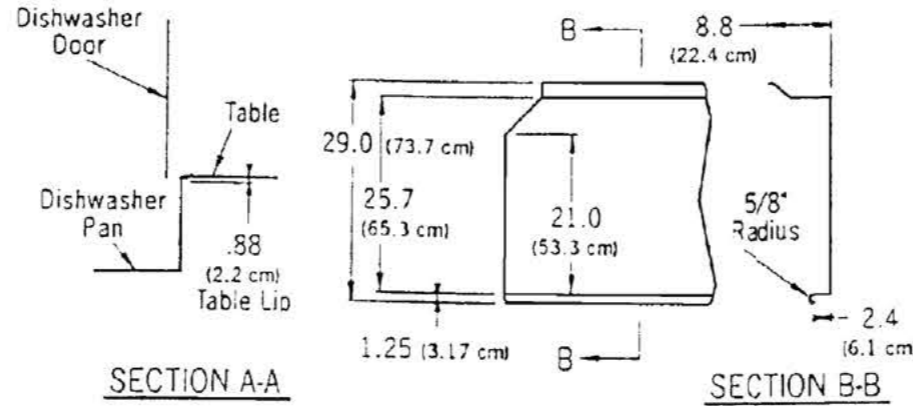

www.TERMAC.com
1.800.332.4912

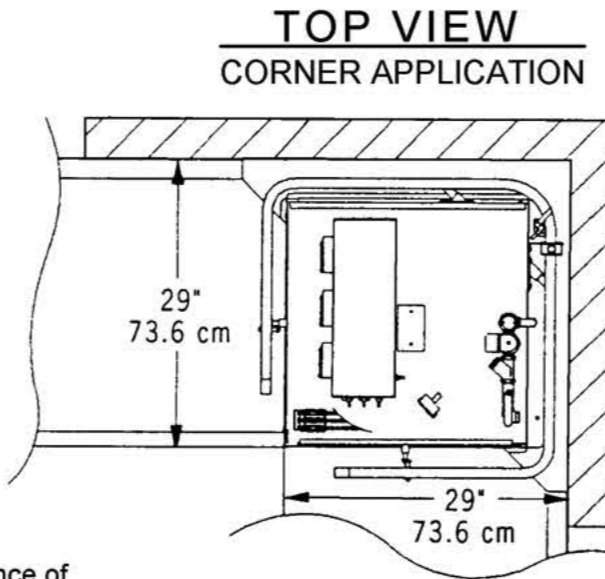
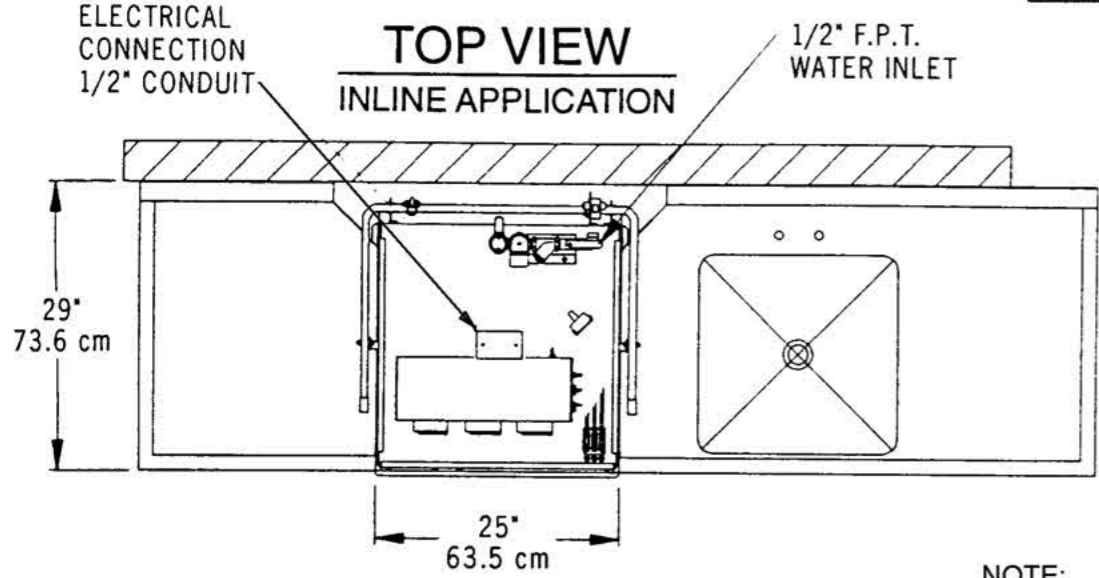

NOTE:
All dimensions listed have a tolerance of + or - 1/8\"/>

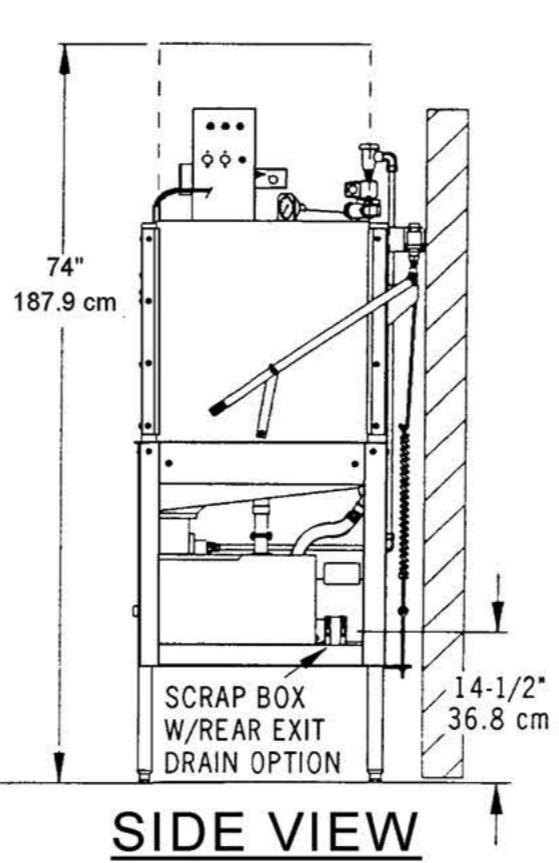
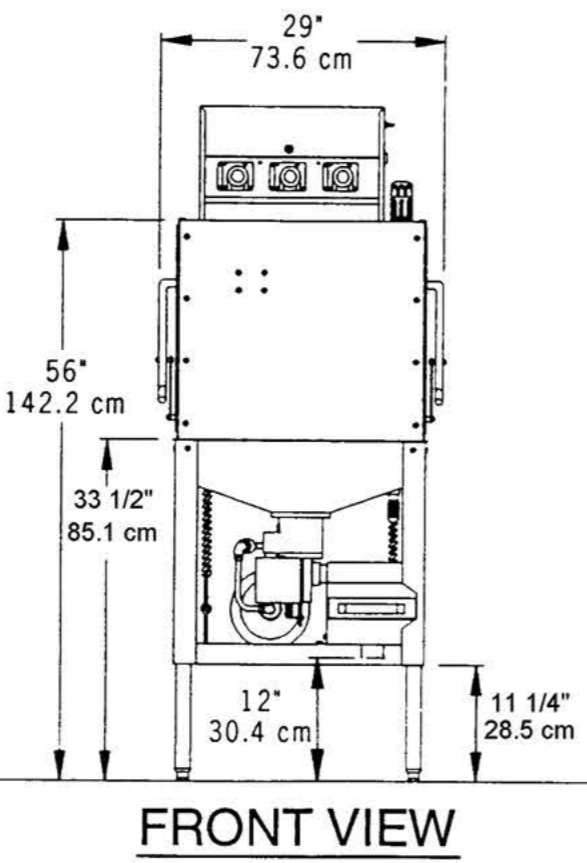
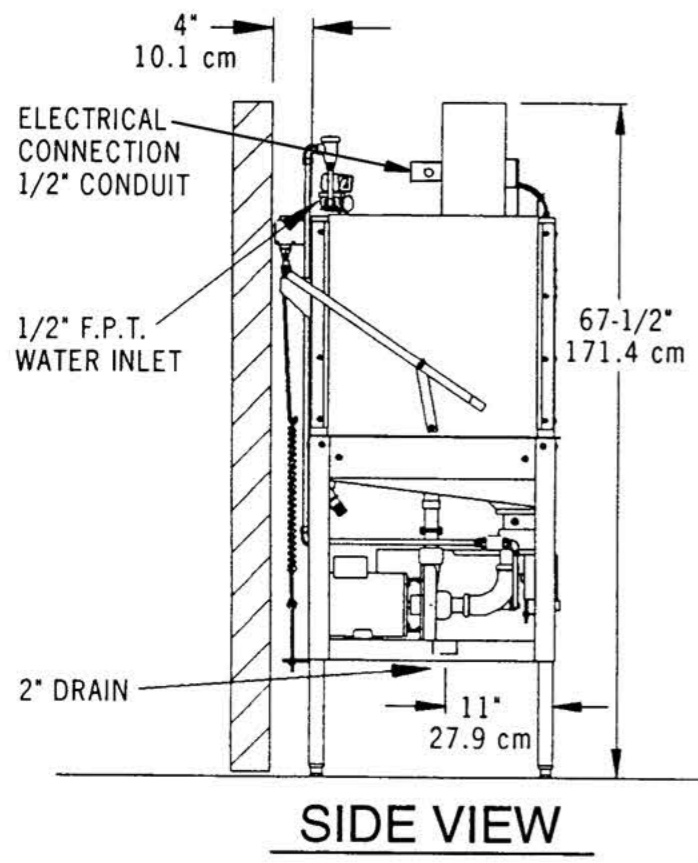

L Series

FAMILY MODELS

	L60-3DW L60-3DWC	L72-3DW L72-3DWC	L90-3DW L90-3DWC
NSF RATED CAPACITY (RACKS/HOUR)	55	46	37
WASH TIME (IN SECONDS)	36	43	50
RINSE TIME (IN SECONDS)	15	19	30
DWELL (IN SECONDS)	09	10	10
GALLONS PER HOUR	66	55	44
TOTAL CYCLE TIME (IN SECONDS)	60	72	90

WATER TEMPERATURE OF SUPPLY WATER (NSF) **120° F. MINIMUM**
or 49. Celsius

WATER CONSUMPTION (NSF RATED) **1.2 GALS. PER CYCLE**
or 4.5 liters/cycle

MOTOR RATING **(1.125 KW) 1.5 HORSEPOWER**

ELECTRICAL RATING (NEC) **115 Vac, 20amp breaker, 50/60Hz, 1 phase**

Connect to Supply Source using 10-12 AWG Copper wires using non-time delay fuse of 20 amp rating or 20 amp circuit breaker.

RACK SIZE **STANDARD 19.75" X 19.75"**
or 50.2 x 50.2 cm

DOOR CLEARANCE **17.75" TALL x 20.75" WIDE**
or 45.1 x 52.7 cm

WATER INLET **(1/2") F.P.T.**

DRAIN SIZE (Scrap Trap) **2" O.D.**

HEIGHT (ADJUSTER FEET WILL GIVE) **MIN: 67.5", MAX: 68.48"**
or 171.5 to 173.9 cm

WIDTH (OVERALL) **29"**
or 73.6 cm

WIDTH, TABLE TO TABLE (INLINE MODEL) **25"**
or 63.5 cm

DEPTH (OVERALL) **28"**
or 71.1 cm

SHIPPING WEIGHT **307 POUNDS**
or 139.2 kg

SHIPPING VOLUME (CRATED) **54.2 CU. FT.**
or 1.53 cu. meters